



## CONTINGENCY AND CRISIS EXECUTION: THE TASKING CYCLE

Last Updated: 04 November 2016

Many Air Force operations are executed by means of a tasking cycle. The cycle is used with some modifications for tasking operations in the air, space, and cyberspace and is the heart of the Air Force commander's [battle rhythm](#). Once execution begins, the commander continues to guide and influence operations through the [air operations directive](#) (and, in some cases, equivalent space and [cyberspace](#) operations directives).

The tasking cycle creates a daily articulation of the overall airpower [strategy](#) and planning efforts. The tasking cycle is the means [Airmen](#) use to accomplish [deliberate](#) and [dynamic targeting](#), among other requirements.<sup>1</sup> The following discussion touches on targeting only as it relates to the tasking cycle and other aspects of an ongoing rhythm of operations. Conceptually, the tasking cycle—its people, processes, and products—forms the connecting link that transitions most airpower planning from the operational to the tactical level.

The tasking cycle develops the products needed to build and execute an [air tasking order](#) (ATO) and related products, and accomplish [assessment](#). Although it is presented below as six separate, sequential stages, in reality **the tasking process is iterative, multidimensional, and sometimes executed in parallel**. It is built on a foundation based on thorough [joint intelligence preparation of the operational environment](#). The cycle typically consists of the following stages performed at various levels of command (illustrated in the figure, "Typical Tasking Cycle"):

- ✦ Assigning [objectives](#), [effects](#), and guidance.
- ✦ [Target development](#).
- ✦ [Weaponeeing and allocation](#).
- ✦ ATO production and dissemination.
- ✦ Execution planning and force execution.
- ✦ Assessment.

---

<sup>1</sup> For further details on the targeting process, see AFDP 3-60, [Targeting](#), and Joint Publication (JP) 3-60, *Joint Targeting*.

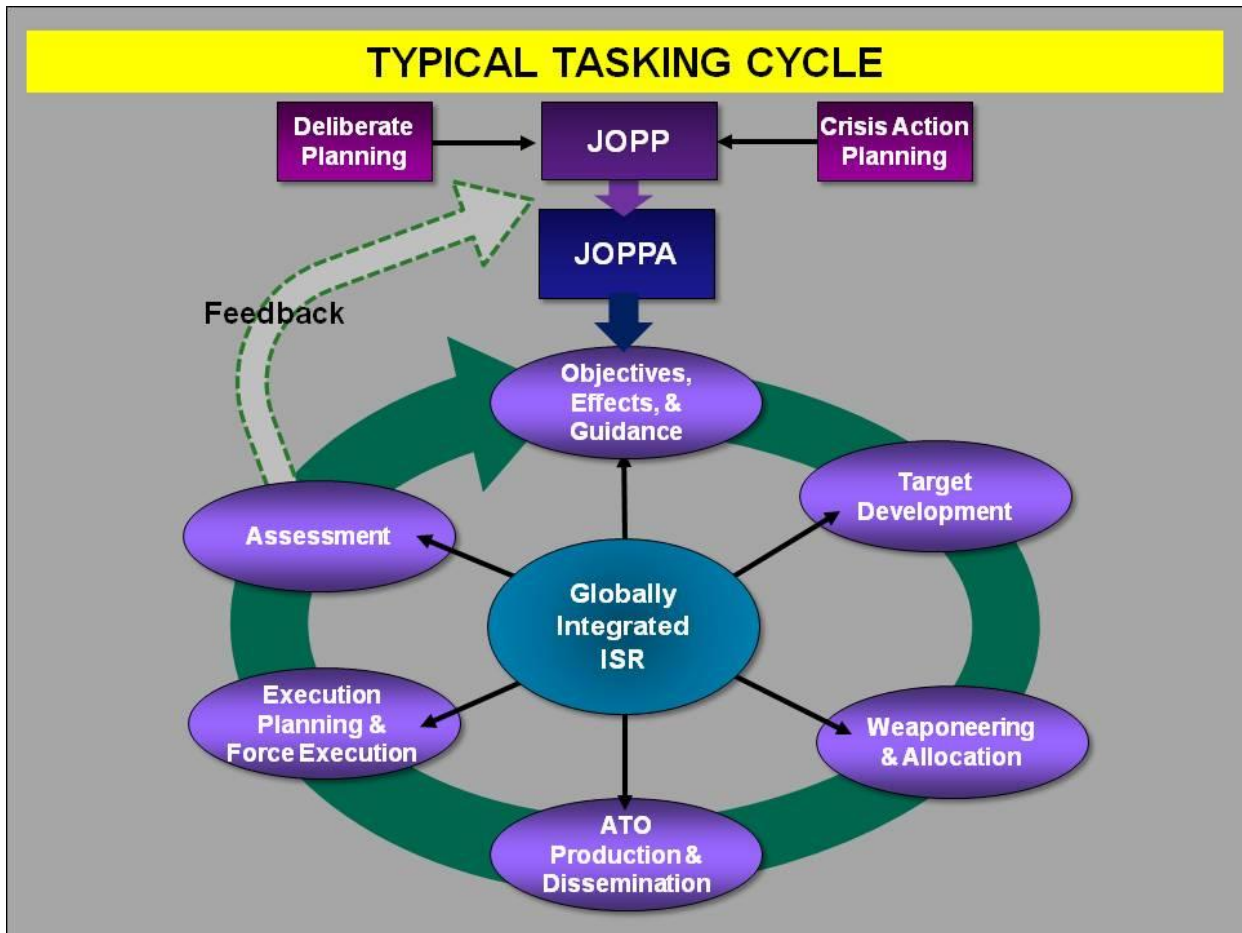

**Typical Tasking Cycle**

*Targeting and ATO production are essential to the tasking cycle. The tasking cycle encompasses the entire process of taking [commanders' intent](#) and guidance, determining when and where to apply force or other actions to fulfill that intent. It matches available capabilities and forces with targets (integrating this effort with the ongoing targeting cycle); puts this information into an integrated, synchronized, and coordinated order; distributes that order to all users; monitors execution of the order to adapt to changes in the operational environment; and assesses the results of that execution. The cycle is built around finite time periods that are required to plan, integrate and coordinate, prepare for, conduct, and assess operations in air, space, and cyberspace. These time periods may vary from theater to theater and much targeting effort may not be bound specifically to the cycle's timeframe, but *the tasking cycle and its constituent processes drive the [air operations center's](#) (AOC's) battle rhythm and thus help determine deadlines and milestones for related processes, including targeting.**

A principal purpose of the tasking cycle is to produce orders and supporting documentation that places an effective array of capabilities in a position to create desired effects in support of joint force objectives. This cycle is driven by the constraints of time and distance. For example, it takes time for ground crews to prepare aircraft for flight, for aircrews to plan missions, and for those crews to fly to the immediate area of operations from distant airfields. Likewise, commanders should have enough visibility on future operations to ensure sufficient assets and crews are available to prepare for and perform tasked missions. These requirements drive the execution of a periodic, repeatable tasking process that allows commanders to plan for upcoming operations.

The ATO (usually 24 hours in duration) and the process that develops it (usually 44-96 hours in duration) are a direct consequence of these physical constraints.

The ATO articulates tasking for joint air, space, and cyberspace operations (unless there are separate space and cyberspace tasking orders) for a specific period, normally 24 hours. Detailed planning generally begins 72 hours prior to the start of execution to properly assess the progress of operations, anticipate enemy actions, make needed adjustments to strategy, and enable integration of all components' requirements. The actual length of the tasking cycle may vary from theater to theater. Length should be based upon [joint force commander](#) (JFC) guidance, the [commander, Air Force forces'](#) (COMAFFOR's) direction, and theater needs. The length should be specified in theater standard operating procedures or other directives. If the length is modified for a particular [contingency](#), this should be specified in the JFC's [operation plan](#) or [operation order](#), in the [joint air operations plan](#), or the COMAFFOR's component plan. The key to both the flexibility and versatility of the tasking process (and both deliberate and dynamic targeting and collection) is a shared understanding among the functional components of anticipated operations in all domains during the period the relevant orders and directives cover. Misperceptions may arise because other components may not have visibility on the wide variety of missions tasked to the COMAFFOR in support of the JFC's objectives and because airpower assets are often tasked to simultaneously conduct missions supporting overlapping operational phases. This shared understanding is largely accomplished by ensuring component liaisons are properly positioned during planning and execution.<sup>2</sup>

In contrast to the misperception that tasking requests must be provided to the (AOC) 72-96 hours in advance to allow targets to be struck by air assets, targets can actually be struck in minutes from when information is made available as part of the dynamic targeting process. Dynamic targeting takes place during the execution planning and force execution stage of the tasking cycle, which commonly corresponds to the mission planning and execution stage of the joint targeting process. Dynamic targeting uses the same basic six steps that apply to all targeting: Find, fix, track, target, engage, and assess (often referred to as F2T2EA), but it occurs in a much more compressed timeline. In dynamic targeting, F2T2EA provides a proven method of directing appropriate action against targets that are in some nature fleeting, emerging, or otherwise "time-sensitive." Dynamic targeting engagements transition from receipt of intelligence ("trigger events"), through target resolution, to action against the target.<sup>3</sup> Additionally, [intelligence, surveillance, and reconnaissance](#) (ISR) assets can collect against *ad hoc* targets via the dynamic collection process through coordination with the senior intelligence duty officer and the ISR division in the AOC.

The net result of the tasking cycle is that there are usually at least five ATOs in various stages of progress at any one time (illustrated in the figure, "Notional AOC Battle Rhythm with Multiple ATOs").

- ✪ At least one ATO undergoing assessment at various levels—Note: due to time lags in gathering and interpreting data from multiple sources, assessment of a given ATO usually occurs over many days.

---

<sup>2</sup> See Air Force Tactics, Techniques, and Procedures (AFTTP) 3-3.AOC, *Operational Employment-Air Operations Center*, for descriptions of the AOC's other Service and functional component liaisons.

<sup>3</sup> See [AFDP 3-60](#) and JP 3-60, for additional information on deliberate and dynamic targeting, and their relation to the larger context of the tasking cycle.

- ★ One currently being executed.
- ★ One in production.
- ★ One in detailed planning (target development and weaponeering).
- ★ One in the strategy development (objectives and guidance) stage.

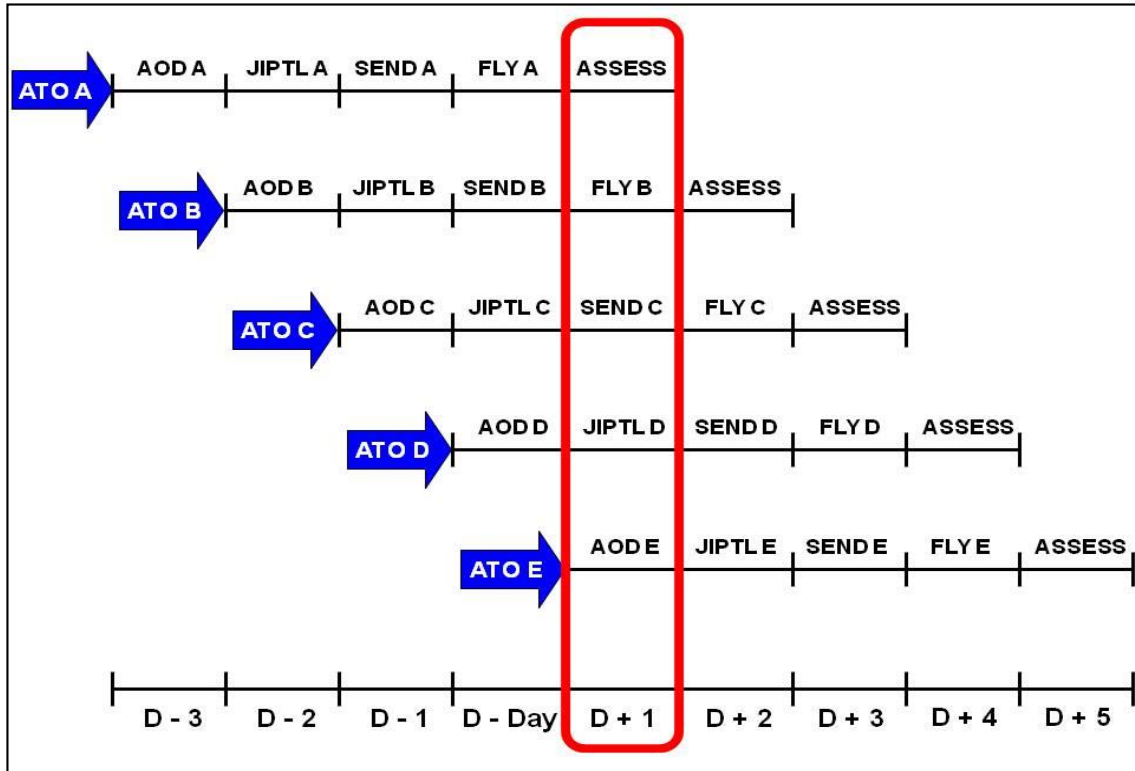

**Notional AOC Battle Rhythm with Multiple ATOs**

Some assets may not operate within the established cycle. These include most space assets, which are tasked via the space tasking order, although some theater-specific space operations will probably be included in the daily ATO for the sake of situational awareness/understanding, integration, and synchronization. Special operations most often operate within the dynamic targeting process. Many [information operations](#) (IO), cyberspace, and intertheater air mobility assets operate within a different cycle as well, and it is critical for AOC planners to include [special operations forces](#), IO, cyberspace, and mobility personnel who can assist with targeting and tasking these capabilities. In large operations, the existence of differing planning cycles among components can lead to increased complexity in the process. Most component planning cycles are approximately 72-96 hours. However, the requirement within the air tasking cycle to manage as many as five separate ATOs drives the requirement for discipline to manage defined inputs and outputs during particular slices of time. Also, dynamic targeting and collection take place within a much more time-constrained framework.

The AOC's combat planners work closely with the [air mobility division](#) to integrate intertheater mobility into the ATO. Some long-range combat assets based outside the [area of responsibility](#), but operating within the [joint operations area](#), may be airborne on a tasked mission before the ATO that covers their weapons' times over target is published. These assets require the most current draft ATO information and all updates that affect their missions. Other missions that are not under the COMAFFOR's control

may be included in the ATO to provide visibility and assist coordination and deconfliction.

*The tasking cycle supports every part of the [joint planning process](#) and the [JPP for air](#), as well as the joint targeting cycle, and is interwoven throughout these other processes up to and including execution planning and force execution. Effective management of the tasking cycle comes at a high cost in terms of the volume and flow of information. Targeting and adversary (or “red”) assessment, which are integrally related, impose a very large collection burden the joint force carries—to support deliberate targeting efforts before, dynamic targeting efforts during, and assessment during and after force execution. Successful execution requires in-depth information on such things as enemy force posture, capabilities, and movement; target vulnerability; enemy leadership’s intentions, habits, and movement practices, and the patterns of enemy behavior. Assessment of friendly capabilities is also critical, and includes feedback on Air Force, joint, and coalition component efforts and capabilities needed for tasking cycle planning and decision-making. The process also takes into account such things as friendly objectives, [concept of operations](#), [rules of engagement](#), target time constraints, and friendly force capabilities.*

---